

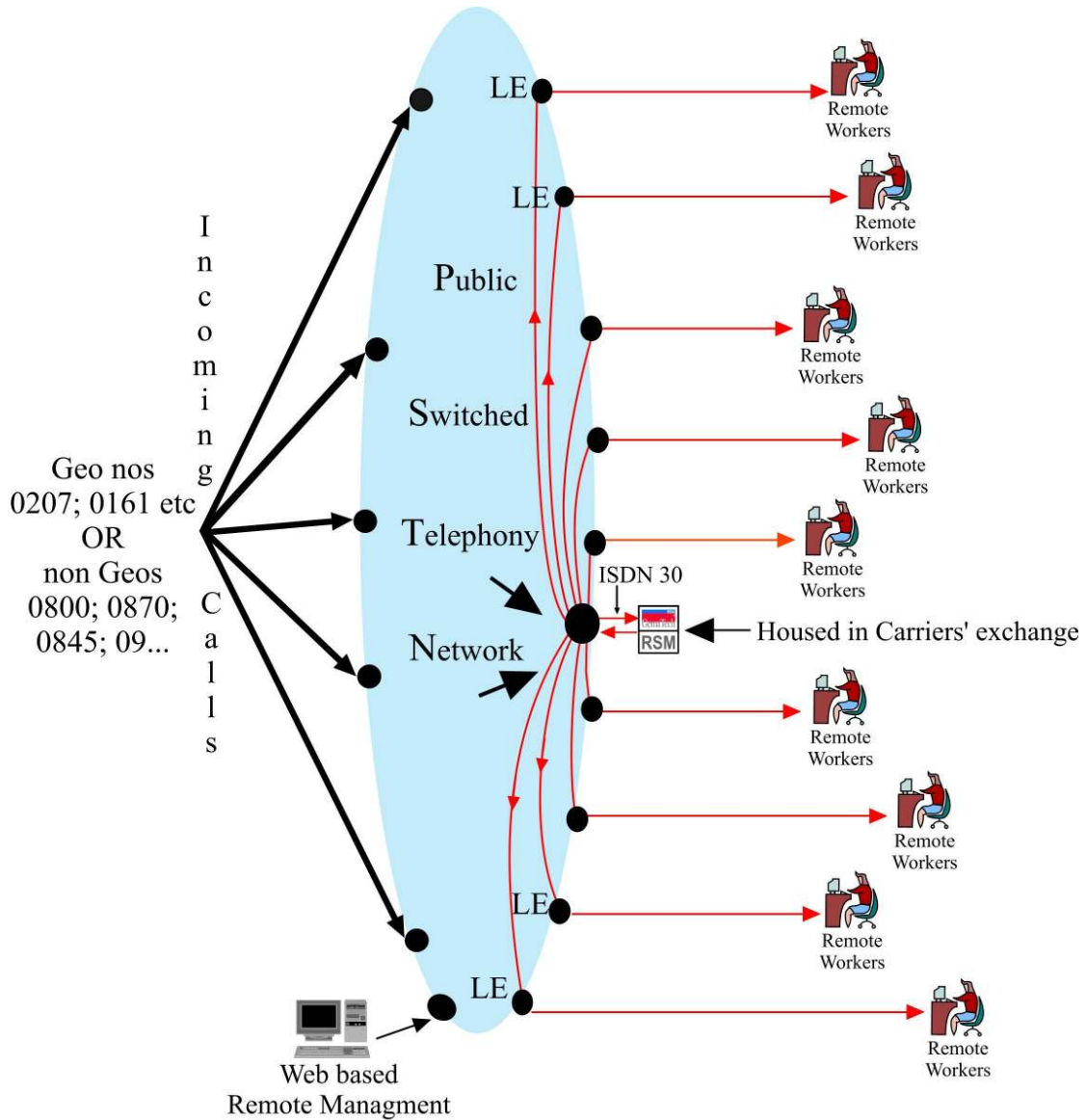

# GemaTech's Virtual Call Centre Product RSM (Remote Service Manager)

## Example 1: Remote ACD – Remote/Homeworking



### LEGEND



-  GemaTech's RSM located in either a selected Tier 1 carrier exchange or a secure, remote location
-  ISDN2 or Broadband connection to remote workers
- LE Local Exchange

# GemaTech's Virtual Call Centre Product RSM (Remote Service Manager)

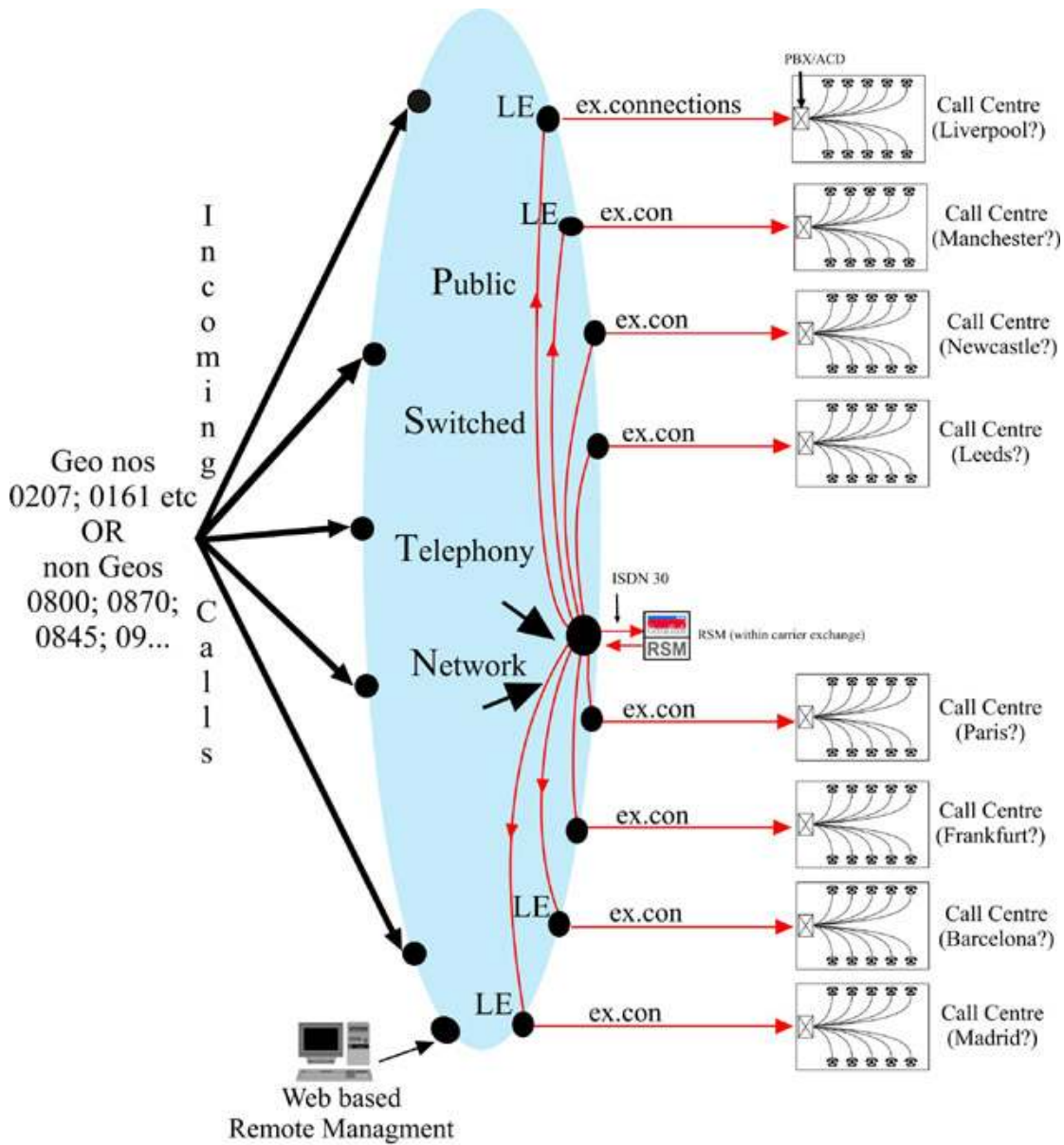
## Example 2: Networked Call Centres





**LEGEND**

-  GemaTech's RSM located in either a selected Tier 1 carrier exchange or a secure, remote location
-  Existing telephone connections (ISDN 30; ISDN 2 or DEL) from office PBX to local exchange
- ex.con Existing connection ie ISDN 30, ISDN 2, Analogue
- LE Local Exchange

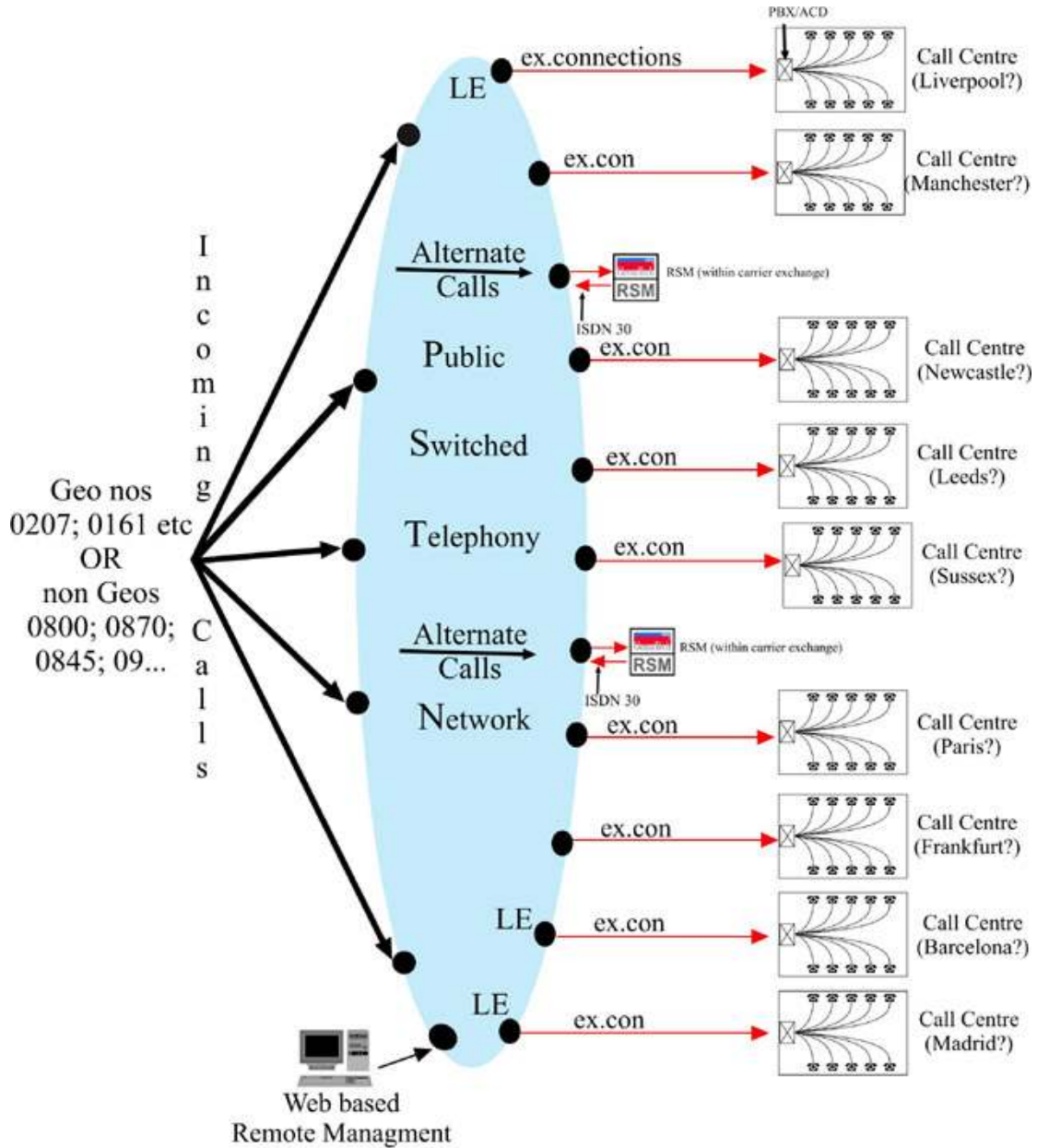
# GemaTech's Virtual Call Centre Product RSM (Remote Service Manager) Example 3: Networked Call Centres Additional Resilience



## LEGEND

-  GemaTech's RSM located in either a selected Tier 1 carrier exchange or a sure, remote location
-  Existing telephone connections (ISDN 30; ISDN 2 or DEL) from office PBX to local exchange
- ex.con Existing connection ie ISDN 30, ISDN 2, Analogue
- LE Local Exchange

# GemaTech's Virtual Call Centre Product RSM (Remote Service Manager) Example 4: Networked Call Centres Migrating to VoIP

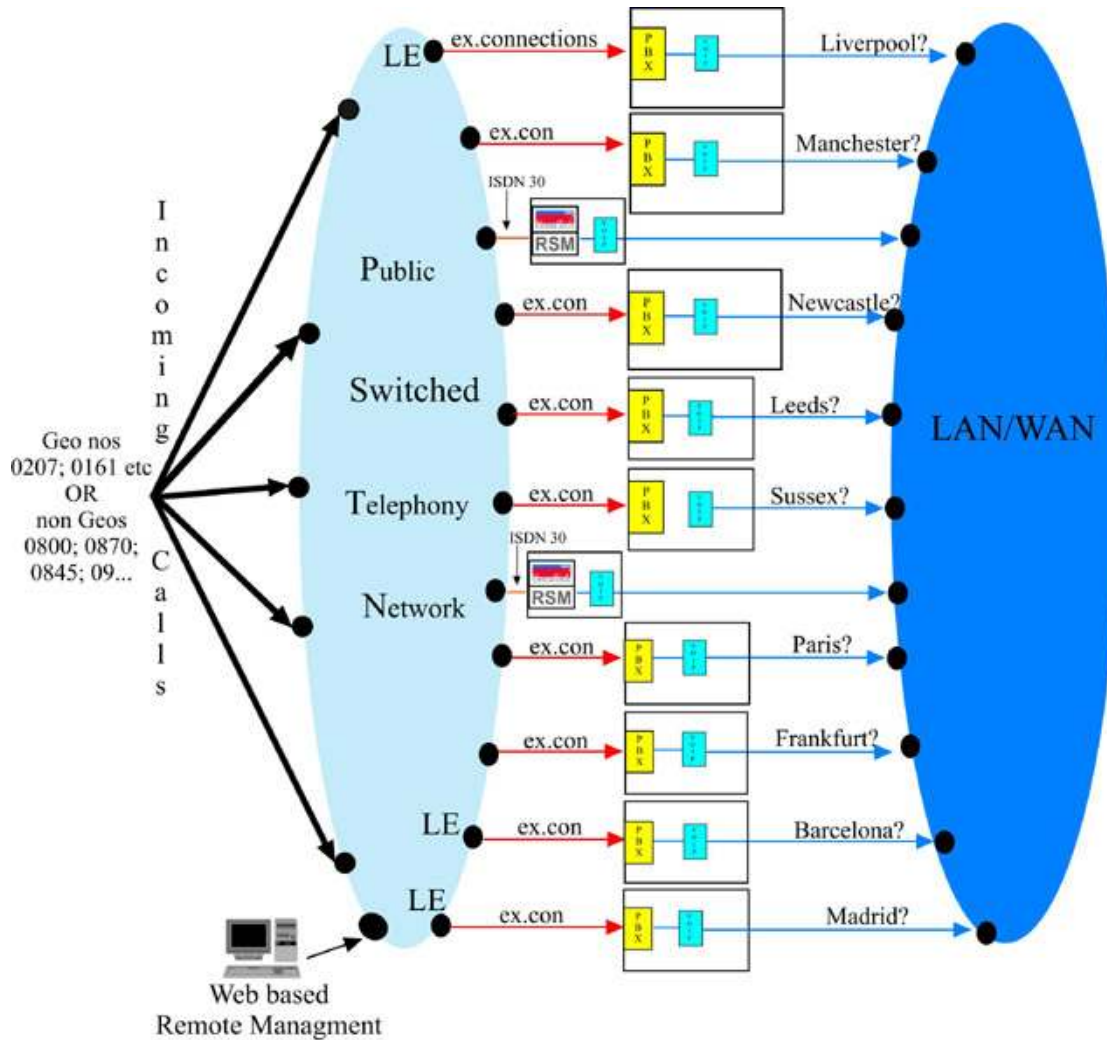

## LEGEND



- GemaTech's RSM located in either a selected Tier 1 carrier exchange or Data Centre
- Existing PBX or replacement IP PBX
- VoIP Gateway to Wide Area Network
- Existing telephone connections (ISDN 30; ISDN 2 or DEL) from office PBX to local exchange
- Data connection to Wide Area Network
- ex.con Existing connection ie ISDN 30, ISDN 2, Analogue
- LE Local Exchange

# GemaTech's Business Continuity Product BCM (Business Continuity Manager)

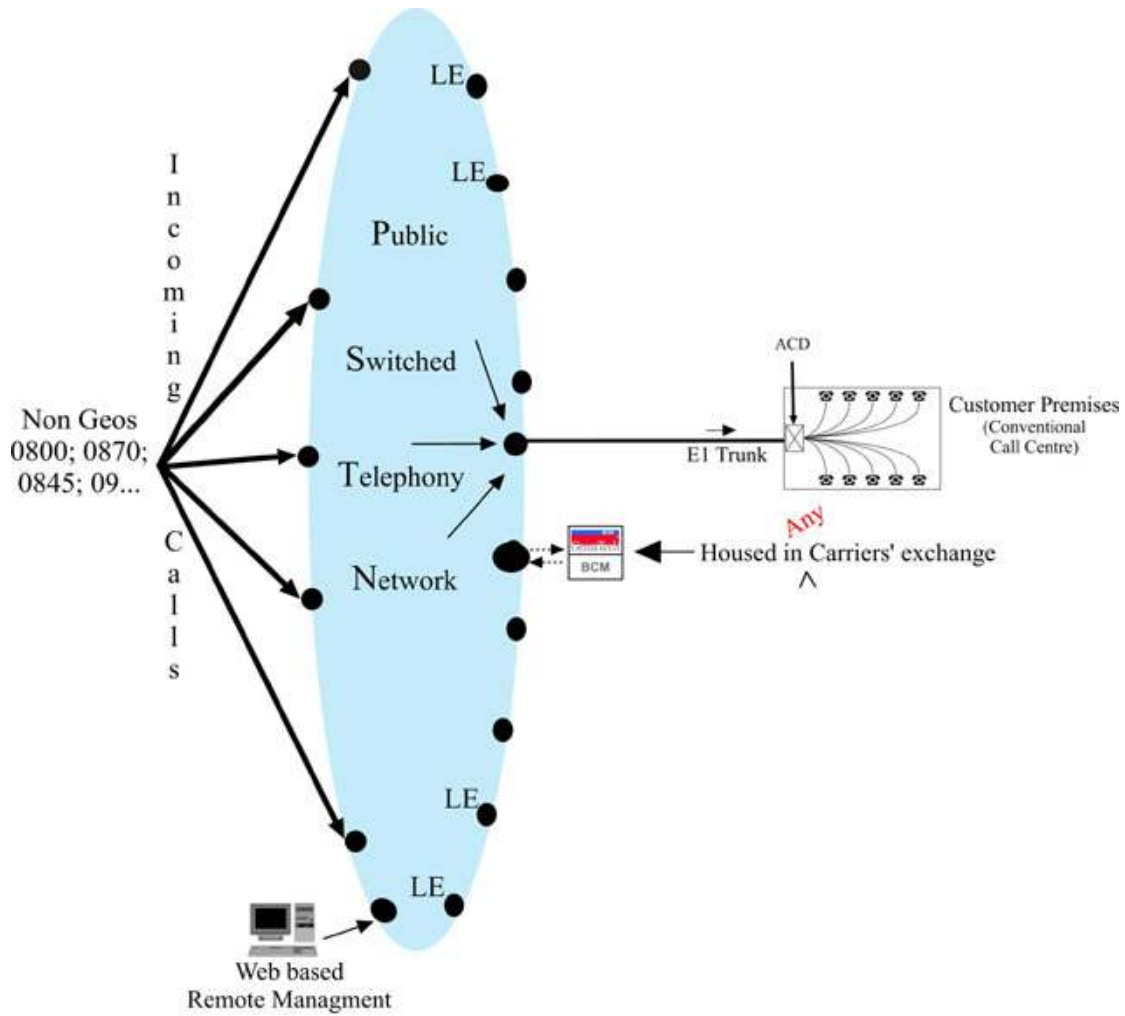
# Example 1: Single Call Centre Recovery Prior to Invocation



## LEGEND



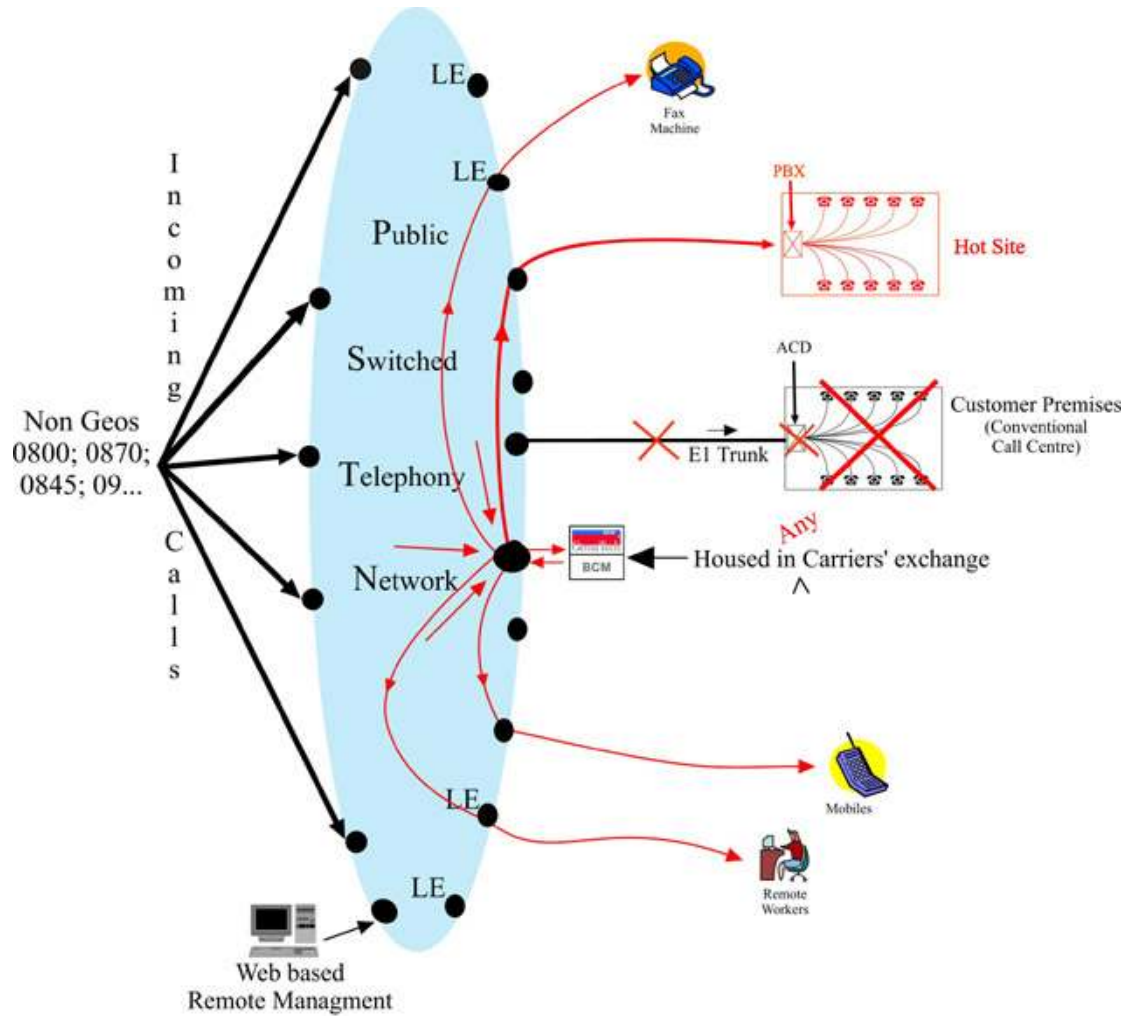

-  GemaTech's BCM located in either a selected Tier 1 carrier exchange or a secure, remote location
-  Existing ISDN 30(s) telephone connections from local exchange to Call Centre ACD
-  ISDN 30(s) connection(s) to GemaTech's BCM
- LE Local Exchange

# GemaTech's Business Continuity Product BCM (Business Continuity Manager)

## Example 1: Single Call Centre Recovery Immediately following Invocation



### LEGEND



-  GemaTech's BCM located in either a selected Tier 1 carrier exchange or a secure, remote location
-  Existing ISDN 30(s) telephone connections from local exchange to Call Centre ACD
-  Redirected calls to Agents relocated to any number of alternative locations
-  ISDN 30(s) connection(s) to GemaTech's BCM
- LE Local Exchange

# GemaTech's Business Continuity Product BCM (Business Continuity Manager)

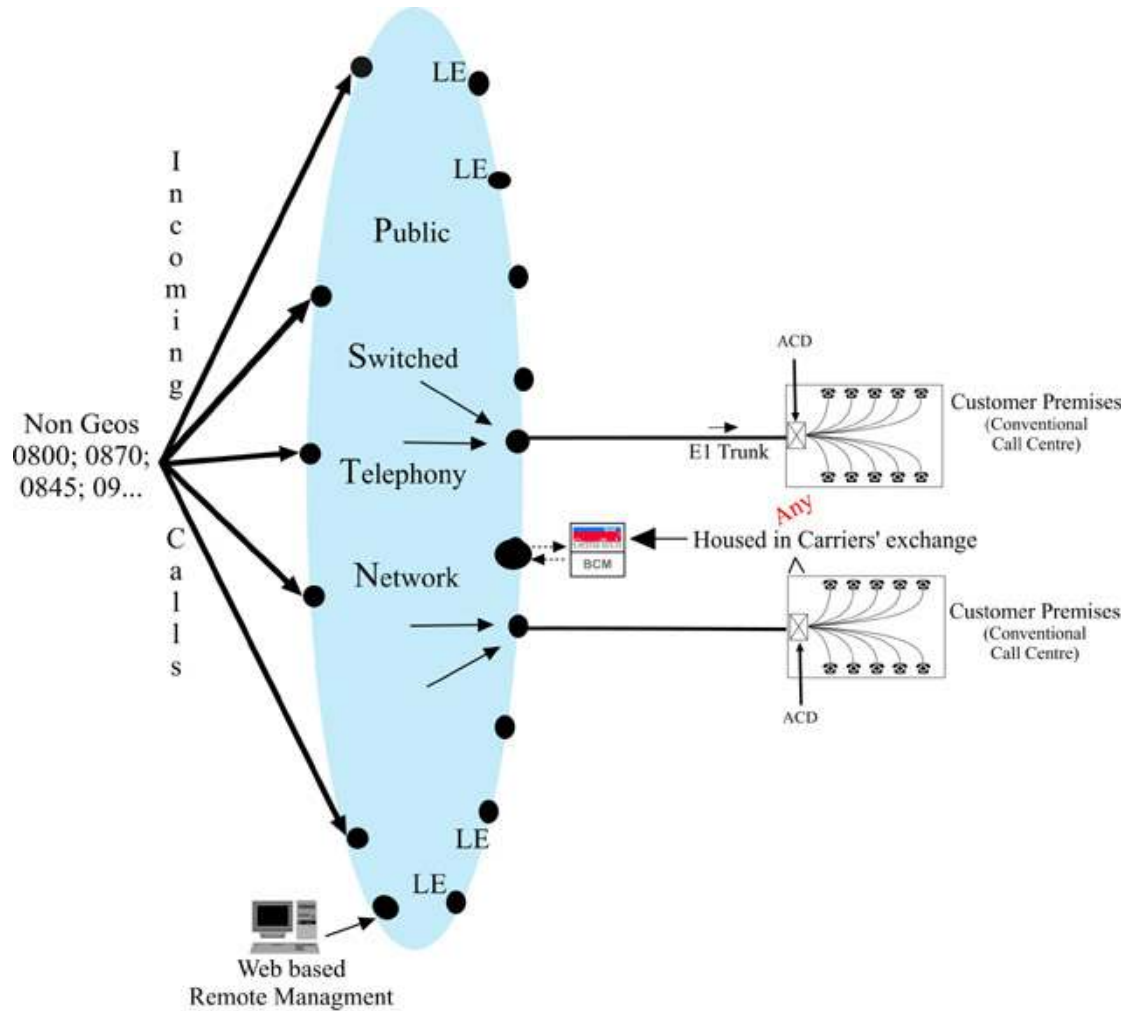
## Example 2: Networked Call Centre Recovery Prior to Invocation



### LEGEND



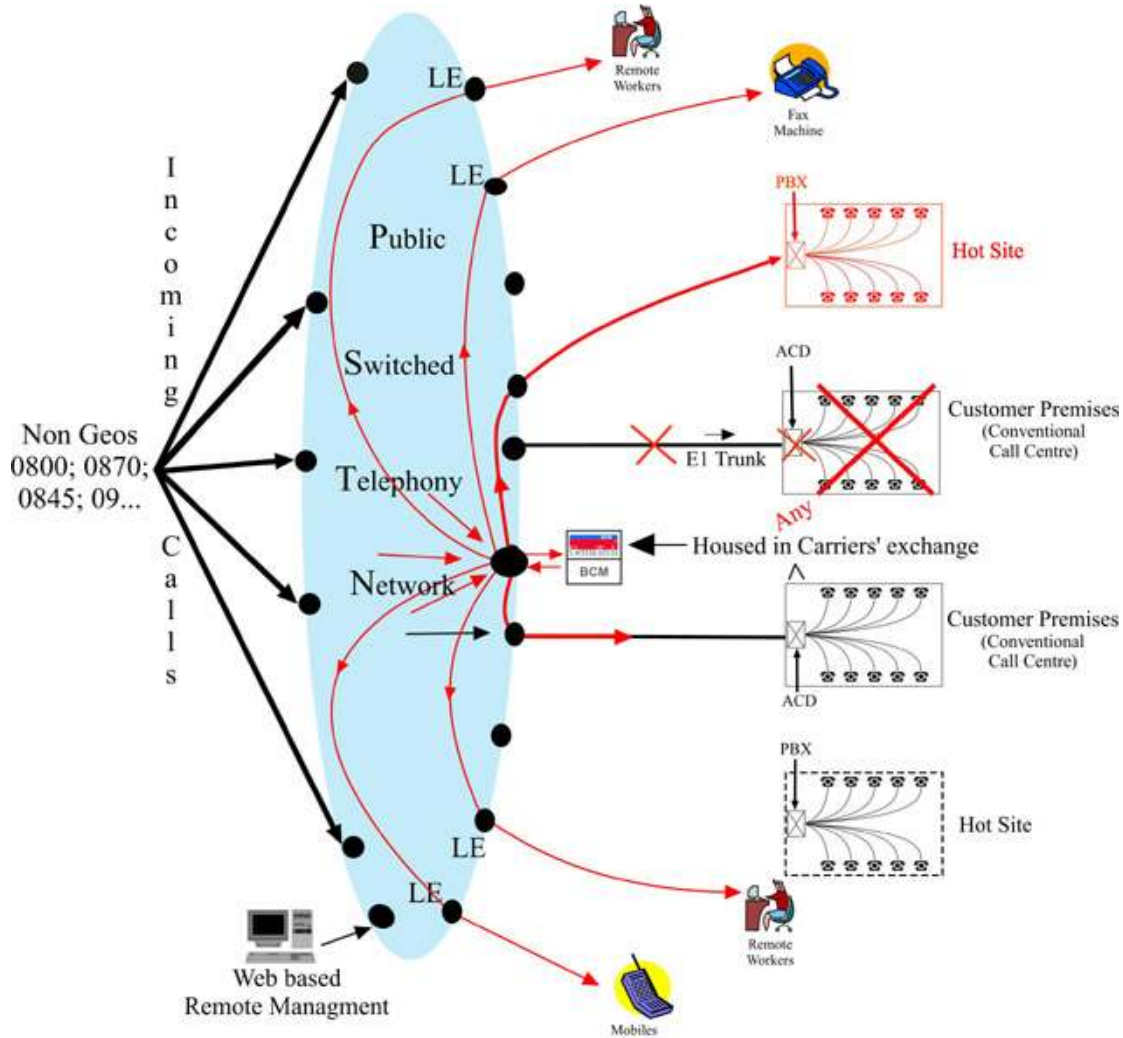

-  GemaTech's BCM located in either a selected Tier 1 carrier exchange or a secure, remote location
-  Existing ISDN 30(s) telephone connections from local exchange to Call Centre ACD
-  ISDN 30(s) connection(s) to GemaTech's BCM
- LE Local Exchange

# GemaTech's Business Continuity Product BCM (Business Continuity Manager)

## Example 2: Networked Call Centre Recovery Immediately following Invocation



### LEGEND

-  GemaTech's BCM located in either a selected Tier 1 carrier exchange or a secure, remote location
-  Existing ISDN 30(s) telephone connections from local exchange to Call Centre ACD
-  Redirected calls to Agents relocated to any number of alternative locations
-  ISDN 30(s) connection(s) to GemaTech's BCM
- LE Local Exchange